

Wireless Connectivity Infrared Thermometer

- Model No. **With Psychrometer**
- MS-WIT022 MS-WIT023
- MS-WIT022K MS-WIT023K



Thank you for purchasing MEET Wireless Connectivity Infrared Thermometer

1. Contents

- Infrared thermometer
- 'K' type temperature Ni-Cr and Ni-Si sensor, temperature range measurable -40°C ~ 250°C (-40°F ~ 482°F) (MS-WIT022K / MS-WIT023K)
- Operating manual
- 1 x 9V (6F22 / 6LR61 / 1604) Battery



- 1 -

3. Description

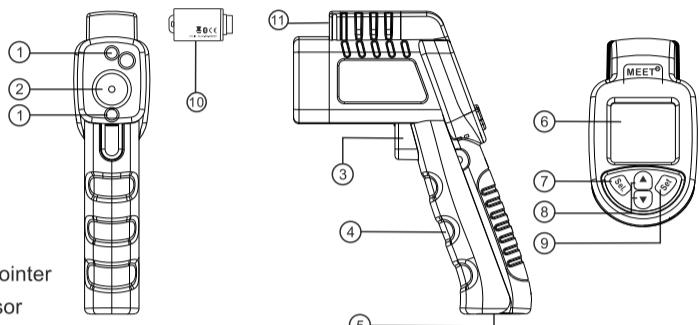

- Dual, Cross Laser pointer
 - IR temperature sensor
 - Trigger / Power on
 - Battery cover
 - 'K' type thermocouple input terminal (MS-WIT022K / MS-WIT023K)
 - LC display
 - Select button
 - Up and Down button
 - Setting button
 - External wireless module
 - External wireless module input slot
- 8) Up and Down button (▲▼)
 Toggling the button for
 a) Object (surface) or ambient (air) or thermocouple ('K' type) (MS-WIT022K / MS-WIT023K) reading
 b) Alm (H) / Alm (L) / ε (emissivity) setting
- 9) Setting button
 Toggling to ON / OFF the L t E / L R S / Alm (H) / Alm (L) / °C / °F / b u Z / b t
- 10) External wireless module
- 11) External wireless module input slot

- 3 -

6. Safety instructions

The meter has been designed for safe use, but must read, understand and follow operating instructions and Safety Rules in this manual before using this product.

Warning

A warning identifies conditions and actions that pose hazards to the user. To avoid electrical shock or personal injury, follow these guidelines.

- Do not point laser directly at eye or indirectly off reflective surfaces.
- Do not use the IR thermometer if it operates abnormally.
- Do not connect the optional external probe to live electrical circuits.
- Do not submerge it in water.
- Do not leave the IR thermometer on or near objects of high temperature.
- Do not operate the IR thermometer around explosive gas, vapor or dust.

7. Care and Handling

- Keep the meter dry. If it gets wet, dry it immediately.
- Use and store the meter in normal temperature. Temperature extremes can shorten the life of the electronic parts and distort or melt plastic parts.
- Handle the meter gently and carefully. Dropping it can damage the electronic parts or the case.
- Keep the meter clean. Wipe the case occasionally with a damp cloth. Do not use chemicals, cleaning solvents, or detergents.
- Use only fresh batteries of the recommended size and type. Remove old or weak batteries so they do not leak and damage the unit.
- If the meter is to be stored for a long period of time the batteries should be removed to prevent damage to the unit.

- 5 -

C) Set button

RELEASE THE TRIGGER BUTTON WHEN SETTING

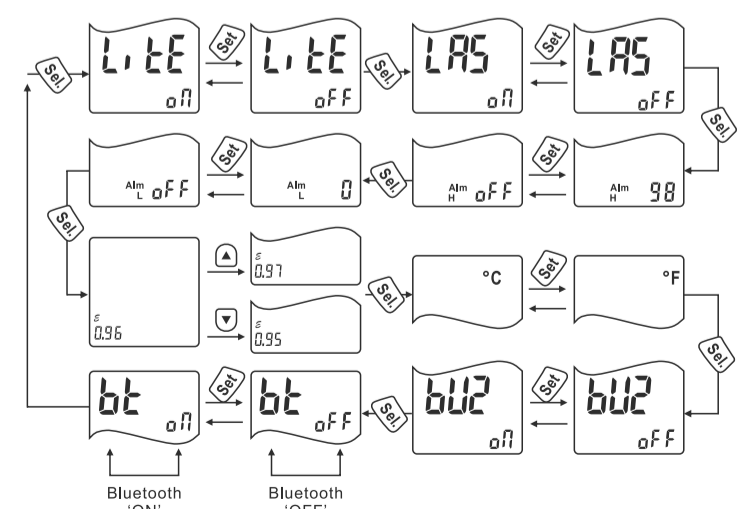

- 7 -

2. Technical Specifications

Model No.	MS-WIT022	MS-WIT022K	MS-WIT023	MS-WIT023K
Psychrometer				Reading by Smart phone
Ambient (Air) from -40°C ~ 85°C (-40°F ~ 185°F)				Typical accuracy $\pm 0.5^{\circ}\text{C}$ / @20°C-60°C
Humidity from 10% RH to 95% RH				Typical accuracy $\pm 2.5\% \text{ RH}$ / @30°C-80°C
Object (Surface) from -50°C ~ 600°C (-58°F ~ 1112°F)	*	*	*	*
Ambient (Air) from -20°C ~ 70°C (-4°F ~ 158°F)	*	*	*	*
Measurable temperature from thermocouple -50°C ~ 1000°C (-58°F ~ 1832°F)		*		*
Dew Point (DP); Wet Bulb (WB); Air temp., Relative Humidity; Grains Per Pound (GPP); Grains Per Kilo (GKG); Vapor Pressure (VP) display on smart phone			*	*
Accuracy (Calibrated with ambient temperature 23°C ± 2°C) $\pm 50^{\circ}\text{C} \pm 1^{\circ}\text{C}$ or $\pm 1\%$ of reading whichever is greater at Calibrated Point (CP)	*	*	*	*
Resolution 0.1°C (0.1°F)	*	*	*	*
Max. / Min. / Diff. / Avg. reading	*	*	*	*
Hi / Lo alarm	*	*	*	*
Emissivity 0.05 ~ 1.00	*	*	*	*
Distance to spot (D:S): 12:1	*	*	*	*
Laser pointer (Dual)	*	*	*	*
Back light	*	*	*	*
Audible sound	*	*	*	*
Hold / Freeze reading	*	*	*	*
'K' type temperature Ni-Cr and Ni-Si sensor, temperature range measurable -40°C ~ 250°C (-40°F ~ 482°F) (included)		*		*
Standalone mode (without external wireless module)	*	*	*	*
Wireless connectivity transmit data to Smart phone / Tablet with iOS APPS or Android APPS (require external wireless module MS-WMB1, sold separately)	*	*	*	*
Data logger compatible (require external wireless with memory module MS-WMBM1, sold separately)	*	*	*	*
Battery powered	1 x 9V (6F22 / 6LR61 / 1604)			
Dimensions (L x W x D) mm	170 x 120 x 42			
Weight (approx.) grams	170 (without battery)			

- 2 -

4. Explanation of symbols and units on the meter

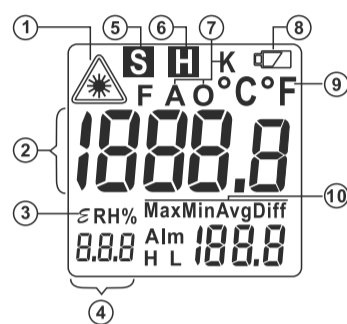

- Laser ON symbol
- Temperature display area
- Emissivity / RH%
- Relative humidity / Emissivity readings display area
- Measuring (scan)
- Hold / Freeze reading
- Triple temperature measuring mode "K" Thermocouple ('K' type) (MS-WIT022K / MS-WIT023K) "A" Ambient (Air) "O" Object (Surface)
- Note: Blinking indicates wireless connectivity 'bt' is ON.
- Low battery indication
- Celsius and Fahrenheit
- Max. / Min. / Avg. / Diff. / Alm. (H) / Alm. (L) reading.

5. How to replace the battery

When low battery warning icon displays on the LCD, open the battery cover and replace a fresh 9V block type battery with negative (-) towards outside. To avoid chemical leakage from the battery, remove the battery if you are intended not to use the meter in short time.

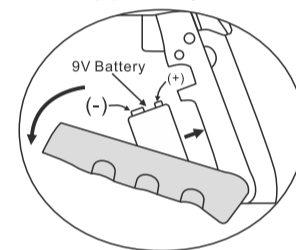

- 4 -

8. How to use the press button

A) Trigger button

Press once the trigger to turn on the unit. Press and hold the trigger button to enter measuring mode (the symbol "S" is blinking) and the measuring value will display on the LCD screen. Release the trigger button, The symbol "H" will appear on the LC. The measured reading is frozen.

B) Select button

RELEASE THE TRIGGER BUTTON WHEN SELECTING

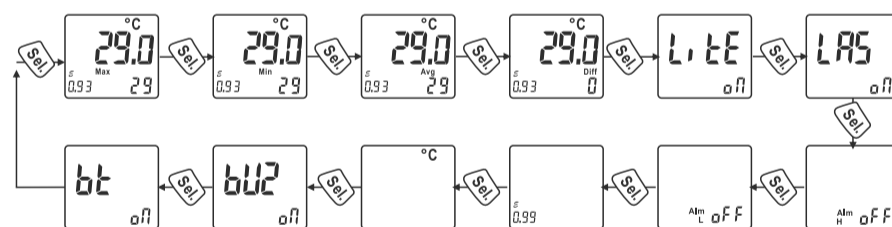

- 6 -

D) UP or DOWN button

RELEASE THE TRIGGER BUTTON WHEN SETTING

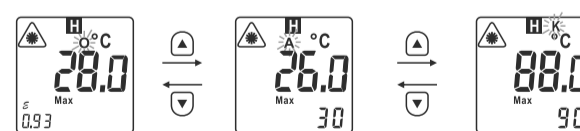

- 1) Available alarm (high and low) setting range for three measuring mode : -50°C ~ 1000°C (-58°F ~ 1832°F)
- 2) Press and hold the UP '▲' or DOWN '▼' button for three seconds, the value increase or decrease automatically

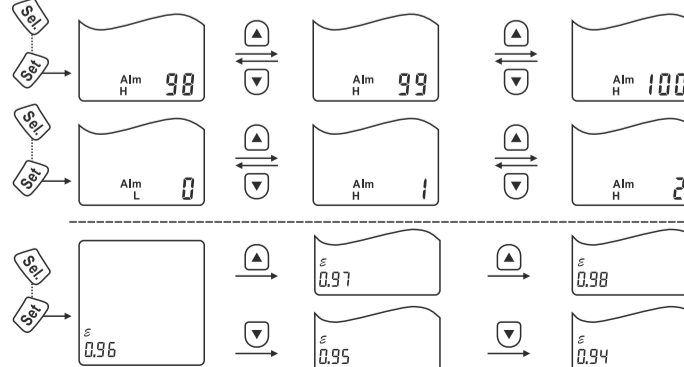

- 8 -

9. Start measurement

A) Object (Surface) :

Infrared thermometer measures the surface temperature of an opaque object. The unit's optics sense emits, reflects and transmits energy, which is collected and focused onto a detector. The unit's electronics translate the information into a displayed temperature reading which appears on the display. The laser is used for aiming purposes only.

- Hold the meter's handle and measure the surface temperature between two laser pointers. For more accurate results, measure the temperature at a Calibrated Point (CP), where two laser aims a 'dot' pointer (approx. one feet from the object).
- IR thermometer turns on when you press the trigger. IR thermometer turns off when no activity is detected for 10 seconds.
- To find a hot or cold spot, aim the unit outside the target area. Then slowly scan across the area with an up and down motion until you locate the hot or cold spot.

Notes:

- The readings are inaccurate if you measure a target with a shiny or metallic surface.
- The unit can not measure full transparent surfaces, such as glass.
- Stem, dust, smoke or other particles can prevent accurate measurement by obstructing the unit optics.

— 9 —

Material	Emissivity	Material	Emissivity
Asphalt	0.90-0.98	Cloth (black)	0.98
Concrete	0.94	Skin (human)	0.98
Cement	0.96	Leather	0.75-0.80
Sand	0.90	Charcoal (powder)	0.96
Soil	0.92-0.96	Lacquer	0.80-0.95
Water	0.92-0.96	Lacquer (matt)	0.97
Ice	0.96-0.98	Rubber (black)	0.94
Snow	0.83	Plastic	0.85-0.95
Glass	0.90-0.95	Wood	0.90
Ceramic	0.90-0.94	Paper	0.70-0.94
Marble	0.94	Chromium Oxides	0.81
Plaster	0.80-0.90	Copper Oxides	0.78
Mortar	0.89-0.91	Iron Oxides	0.78-0.82
Brick	0.93-0.96	Textiles	0.90

B) Ambient (Air):

- The thermometer turns on when you press the trigger.
- Press UP '▲' or DOWN '▼' button, "A" symbol and temperature value appear on the LCD.
- Press the trigger, the unit turns on and the current ambient temperature value will appear on the LCD. Also, for MS-WIT023 / MS-WIT023K humidity readings will appear at left bottom area of the screen.

C) Thermocouple ('K' type) (MS-WIT022K / MS-WIT023K):

⚠ To avoid electrical shock or personal injury, do not connect the optional external probe to live electrical circuits.

- Connect the probe to the input on the unit. Then press UP '▲' or DOWN '▼' button, "K" symbol and temperature value appear on the LCD.
- Use the temperature probe to measure the target, the reading is current temperature after the display is stable.

Note: When moving from temperature / humidity extreme to another, allow time for the meter to stabilize.

— 11 —

d) Distance and spot size (D:S=12:1)

As the distance (D) from the target being measured increases, the spot size (S) of the area measured by the unit becomes larger. The spot size indicates 90% encircled energy. The maximum D:S is obtained when the IR Thermometer is 600mm (24 in) from the target resulting in a spot size of 50mm (2 in). See the following figure.

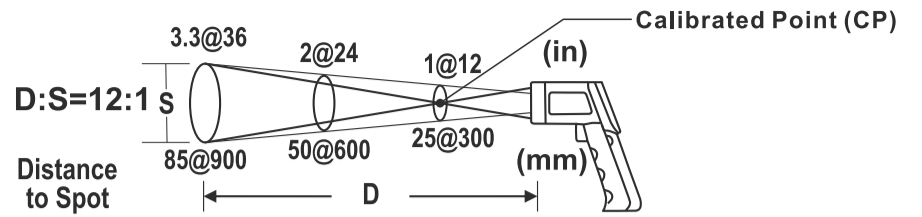

- For more accurate results, measure the temperature moving (aiming) the two laser at a 'dot' point.

- Field of view**
Make sure that the target is larger than the spot size. The smaller the target, you will be more closer to it.

- Emissivity**
Emissivity describes the energy-emitting characteristics of materials. Most organic materials and painted or oxidized surfaces have an emissivity of about 0.95. If possible, to compensate for inaccurate readings that may result from measuring shiny metal surfaces, cover the surface to be measured with masking tape or flat black paint and use the high emissivity setting. Allow time for the tape or paint to reach the same temperature as the surface beneath it. Measure the temperature of the tape or painted surface.

— 10 —

10. Trouble Shooting

By purchasing the meter, you have acquired a product which has been designed to the state of the art and is operationally reliable. Nevertheless, problems or faults may occur. For this reason, the following is a description of how you can eliminate possible malfunctions yourself.

⚠ Always adhere to the safety instructions !

Error	Possible cause
The meter does not function.	Are the batteries dead ? Check the status.
No measuring value change.	Is the wrong measuring function active?
Reading on display hangs up.	Release the trigger to 'OFF' position and then starts again after 3 seconds.
Fatal error or undefined reading.	Release the trigger to 'OFF' position and then starts again after 3 seconds.

⚠ Repairs other than those described above should only be carried out by an authorised specialist.

* Product specifications subject to change without notice

— 12 —

Wireless Connectivity

1. Operating the Smart phone / Tablet and the meter

- Require external wireless module, either
 - MS-WMB1 (external wireless module)
 - MS-WMBM1 (external wireless with memory module, for data logging)

- Download free 'iDMMD' / 'iMEET' iOS APPS from App Store or scan below QR code.

- Download free 'iMEET' Android APPS from Google Play Store or scan below QR code.



— 13 —

2. Reading display on Smart phone / Tablet



Digital display



Analogue display (Turn clockwise)



Real time graphic display (Turn anticlockwise)



Capture picture with data on screen display



Historical storage / data filling



Historical storage / photo with data filing



Send / share file or photo

— 15 —

- Click the APPS icon to start connectivity.

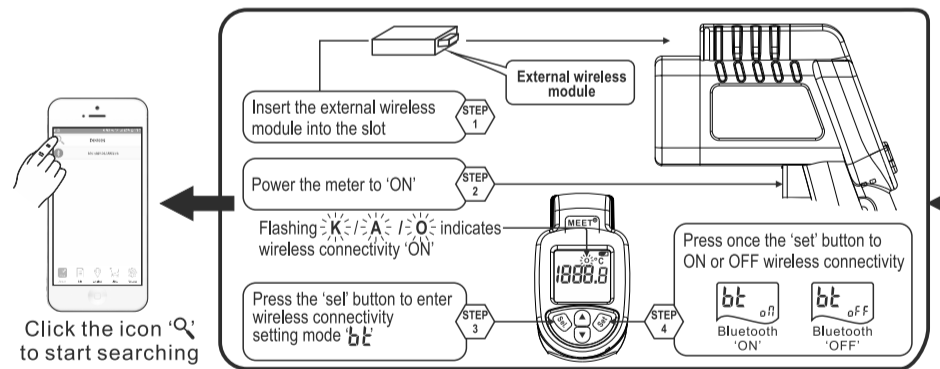
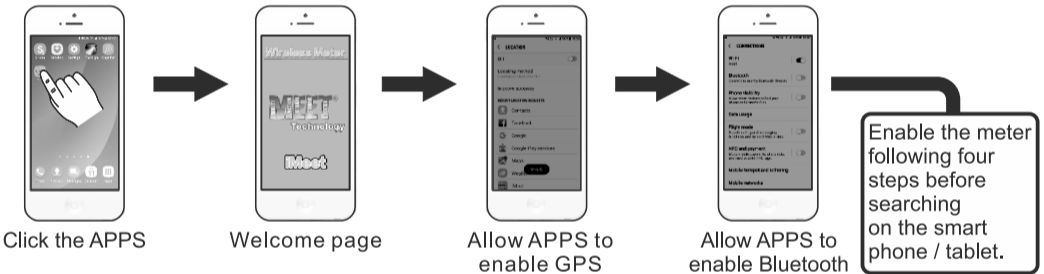

— 14 —

3. Exit from wireless connectivity function

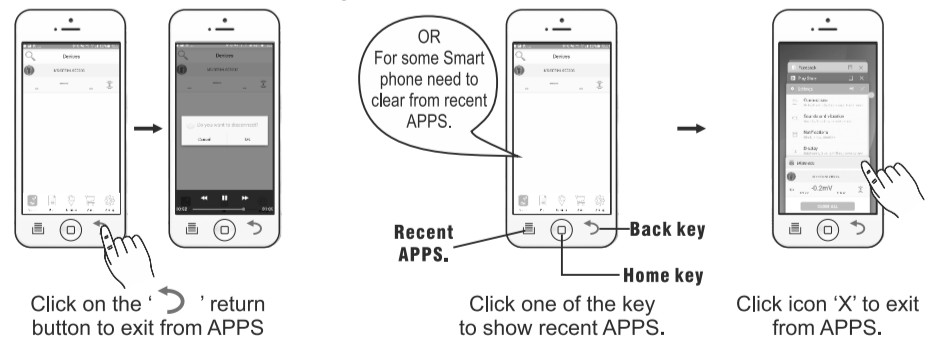

Note:

- Remember to disconnect the 'Wireless connectivity' APPS from the Smart phone / Tablet when not in use.
- You may connect the 'Wireless connectivity' if you need to always monitor the meter, but this will restrict the other user can't use the meter at same time.

4. Data logging

Use part no. MS-WMBM1 external wireless module with memory for data logger

- Setting option for data logging is included in same APPS.



Data Logger Compatible

- Features and specifications are subject to change without prior notice.
- All trademarks are the property of their respective owners.
Copyright © 2016 Meet International Ltd. All rights reserved www.meet.com.hk

— 16 —